

# PROCOL

MONITORING AND DIRECTIONAL CONTROL OF SOLIDS

**PC DIVERTER VALVES**

**TWIN VANE SCALE VALVES**

**ROTARY SCALE VALVES**

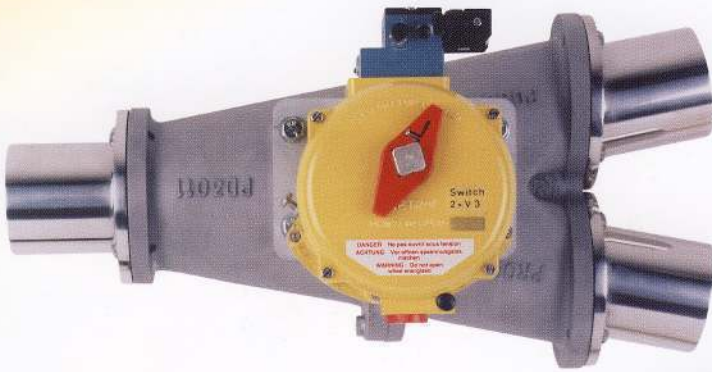

THE DOWSON GROUP

## PC DIVERTER VALVES

Procol PC Diverters are designed to route product flow in dilute and medium phase pneumatic conveying systems handling mild or none abrasive products.

They are available in three standard configurations:

- 'ST' Type (Straight through)
- 'Y' Type
- Parallel

Procol PC Diverters have cast bodies fitted with stainless steel vane

assemblies mounted in phosphor bronze bearings. The vane has a self adjusting polyurethane seal which bears on a fully machined surface to ensure a high sealing efficiency. Changes in cross sectional area are minimised through the valve to reduce conveying line pressure drop.

The Diverters are supplied with plain spigot connections as standard. Flanged connections conforming to a wide variety of pipe standards are available as an option.

Valve actuation may be manual,

pneumatic or electrically operated and are available with with various material options.

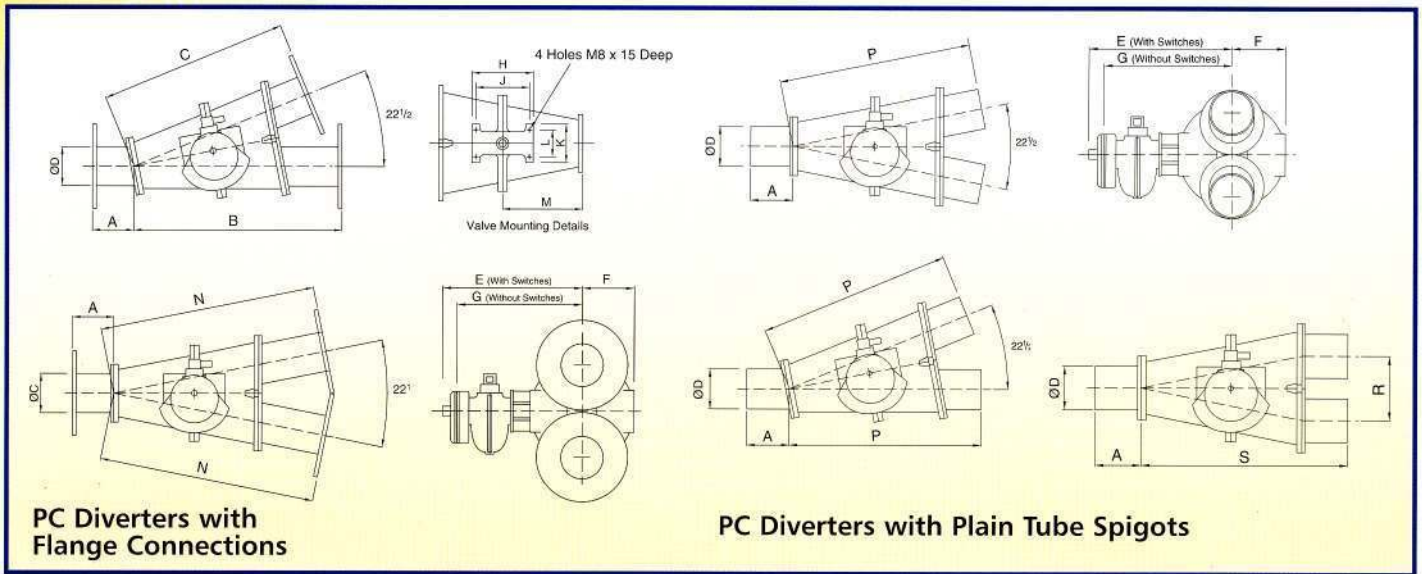

Valve Size	A	B	C	D	E	F	G	H	J	K	L	M	N	P	R	S
50 - 2"	80	390	340	2"	245	80	190	140	124	80	60	136	450	340	100	330
75 - 3"	85	530	480	3"	265	100	210	140	124	80	60	169	550	395	120	390
100 - 4"	110	660	610	4"	340	125	295	160	140	100	70	210	600	495	150	490
125 - 5"	110	800	750	5"	390	175	345	160	140	100	70	327	650	625	200	615
150 - 6"	110	830	780	6"	390	175	345	160	140	100	70	300	750	665	216	655

## Rotary Scale Valves

Valve Size	A	B	C	D	E	F	G	H	J	K	L	M	N
50	2"												
75	3"	100	575	285	240	325	245	170	12	300	330	256	104
100	4"												
125	5"	150	675	355	320	440	320	220	12	400	430	356	154
150	6"												



Mounting Flange Detail

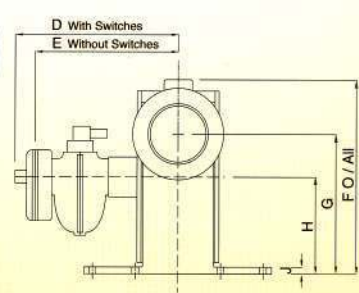

## TWIN VANE SCALE VALVES

Procol Twin Vane Divertors (Scale Valves) are designed to transfer product directly from a pneumatic conveying system into a weigh hopper. They are also used in multiple silo installations where they allow the use of a single conveying line and venting system. Considerable cost savings can be achieved by using Divertors in this way.

The valves are similar in design to

Procol PC Diverter Valves. To ensure consistent weighments the vanes are operated by twin pneumatic actuators which operate simultaneously to affect a snap action cut-off

Various material options are available and the valves can be supplied with flanged connections if required.

### OPERATING METHOD

The valves are initially set with both vanes in the lower position as shown in Figure 1. This isolates the weigh hopper from the conveying system and allows product to pass over the

hopper. When the valve is operated the vanes move to the raised position shown in Figure 2, which allows product and air to enter the weigh hopper. The product and air separate in the hopper and the air is returned to the conveying line via the return port in the valve base.

When the correct weight is reached the vanes snap to the lower position which again isolates the hopper from the conveying line and allows excess product to be returned to the main store silo via the conveying system.



Figure 1

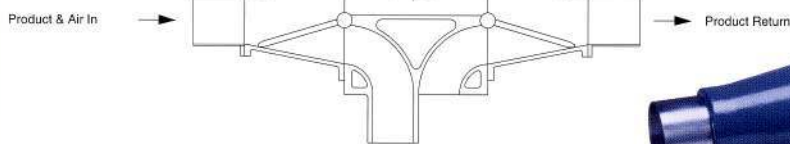
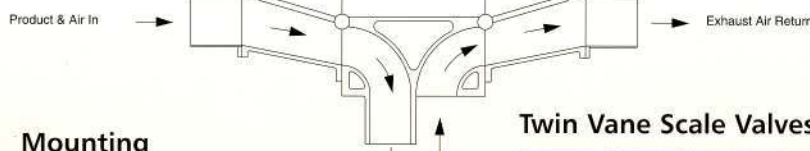
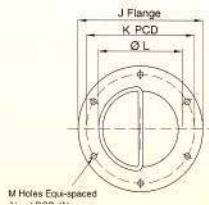

Figure 2



### Mounting Flange Detail



### Twin Vane Scale Valves

#### Valve

Valve Size	A	B	C	D	E	F	G	H	J	K	L	M	N
50	2"	80	645	245	225	100	105	10	194	166	134	4	10
75	3"	85	730	265	250	100	130	12	250	210	166	6	10
100	4"	110	940	340	265	100	140	30	300	260	205	6	14
125	5"	110	1425	390	410	150	235	30	445	400	300	10	22
150	6"	110	1370	390	410	150	235	30	445	400	300	10	22

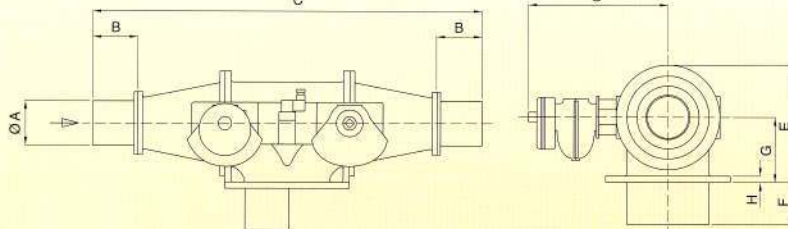

## ROTARY SCALE VALVES

Rotary Scale Valves are designed for in-flow product diversion directly from a pneumatic conveying system into bulk storage and weigh hoppers. They are suitable for handling powders and granules in a wide range of industries.

The valve has a precision machined cast iron body and endplates. It is fitted with a cast iron precision machined vane, supported by phosphor bronze bushes within the

endplates and operated by a direct coupled pneumatic actuator. The valves are supplied complete with indicator switches and a solenoid operated spring return air control valve.

Rotary Scale Valves are available in two body sizes. However the use of connecting tube adaptors enable them to be used in conveying systems from 1 1/2" to 6" diameter.

The valves may be used with product flow from either direction and with various solenoid voltages but other variations are not available.

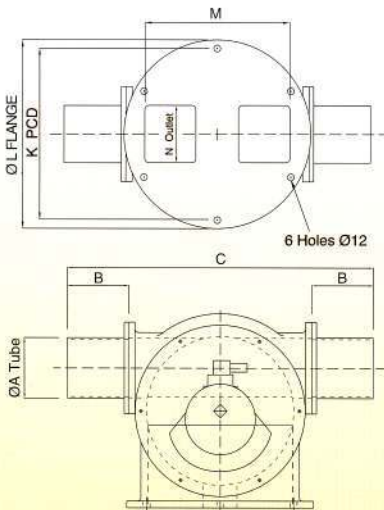



THE DOWSON GROUP

www.dowsongroup.com

**OPTIONS**

- ▶ Electrically actuated.
- ▶ High temperature valves.
- ▶ Abrasion resistant internal coatings.
- ▶ Special paint finishes

**STANDARD SPECIFICATION**

	PC Diverter Valves	Twin Vane Scale Valves	Rotary Scale Valves
<b>Body</b>			
Cast Iron	✓	✓	✓
LM 25 Aluminium Alloy	✓	✓	●
316 Stainless Steel	✓	✓	●
<b>Vane Assembly</b>			
Cast Iron	●	●	✓
Fabricated grade 316 Stainless Steel	✓	✓	●
<b>Vane Seal</b>			
Heavy duty Polyurethane suitable for 80°C maximum	✓	✓	●
<b>Bearings</b>			
Phosphor Bronze	✓	✓	✓
<b>Shaft Seals</b>			
Nitrile rubber 'O' ring seals	✓	✓	●
<b>Actuation</b>			
Double acting quarter turn pneumatic actuator	✓	✓	✓
<b>Air Control Valve</b>			
Single solenoid operated, spring return air control valve Solenoid voltage to customer requirements.	✓	✓	✓
<b>Indication Switches</b>			
Zoff Mechanical limit switches mounted in an IP65 enclosure and wired for SPDT operation.	✓	✓	✓
<b>DESIGN PARAMETERS</b>			
Positive Pressure Systems: 2 barg	✓	✓	✓
Negative Pressure Systems: 300 mbarg	✓	●	✓
Maximum Temperature: 80°C Standard Valve	✓	✓	✓
240°C High Temp Valve	✓	✓	●
Compressed Air Supply: 5 barg Minimum	✓	✓	✓
7 barg Maximum	✓	✓	✓

● Not Available

**BRITTON VALVES**

- 2 Way Slide Diverters**  
Hand Crank Operated Slide Valves
- 2 Way Vane Diverters**  
Air Operated Slide Valves
- Hand Operated Slide Valves**  
Fabricated Slide Valves

**DOWSON HANDLING**

- Standard Screw Conveyors**  
Samplers
- Special Screw Conveyors**  
Automatic Sampling Systems
- Screw Conveyor Components**  
Bin Activators
- Multi Worm Screw Feeders**  
Volumetric Feeders
- Big Bag Loaders**

**HELITEC**

- Manufacturers of Screw Conveyor Segments in Mild and Stainless Steel**  
Maximum Diameter: 1800mm  
Maximum Material Thickness: 20mm

**PROCOL SALES**

- Rotary Valves**  
Pneumatic Conveying Diverters
- Rotary Blowing Seals**  
PC Divertors (Scale Valves)
- Fabricated Rotary Valves**  
Double Flap Valves
- Heavy Duty Gravity Diverters**  
Butterfly Valves
- 3 Way Gravity Diverters**  
Butterfly Dampers
- Special Slide Valves**  
Slide Dampers

**WRIGHTS (GAMLINGAY) LTD**

- STANDARD PRODUCTS**  
Gravity Roller Conveyors  
Powered Roller Conveyors  
Accumulating Roller Conveyors  
Table Top (Slat) Conveyors  
Elevators  
Racking  
Installation  
General Fabrication
- SPECIAL PRODUCTS**  
Consultancy  
Design Studies  
Turnkey Project Management  
Custom Built Conveyor Systems  
All Types of Automation.



PROCOL SALES

10 Purbeck Drive, West Bridgford,  
Nottingham NG2 7AU.  
Tel: 0115 846 9469. Fax: 0115 846 1834.  
E-mail sales@procol.dowsongroup.com